

Minimum distance to obstruction in front 1000mm

200mm reinforced concrete base slab (C50) with x2 layers A142 fabric on 300mm well consolidated hardcore

100mm Dia duct at 700mm deep with slow bend up to slab level. Duct to be marked "Electricity" (for Jersey Electricity use only).

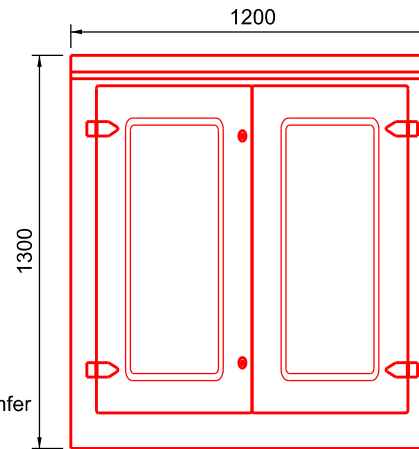
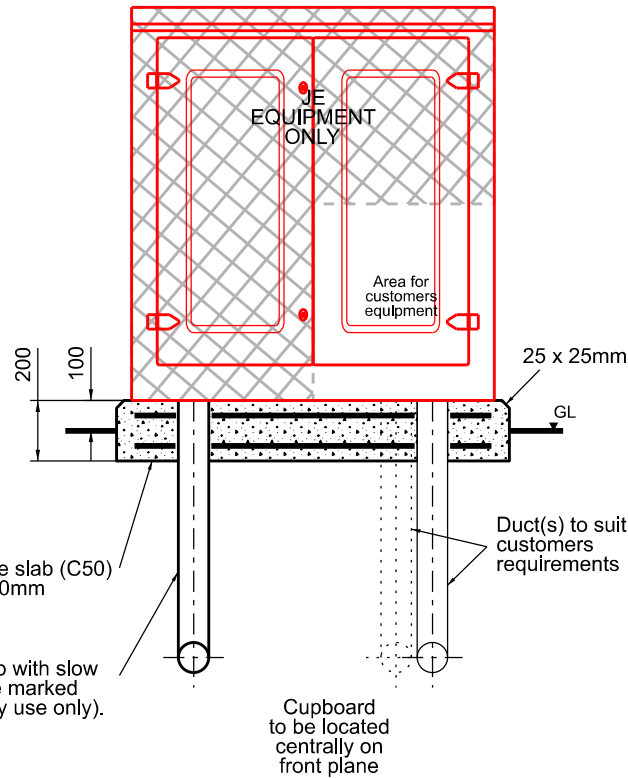

Depth : 490mm

Requirements:

- Minimum internal depth 250mm
- Door may open to left or right
- Door frame to provide a rain proof seal
- Approved lock to be fitted
- 16mm Plywood backboard to be in good condition and may be encased in a layer of fiberglass
- Duct to be flush with top of slab
- All access holes for ducts to be cut neatly with hole saw, in line with duct. Minimum dimensions from hole to rear of cupboard 25mm
- Duct for customer cable to be installed as indicated flush to bottom of box away from the location of Jersey Electricity equipment
- Cupboard to be securely fixed to plinth
- Ownership and maintenance is the responsibility of the customer
- The cupboard can, may be manufactured in any colour
- Available from Rosden Ltd. at La Collette

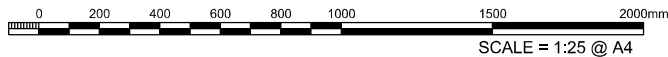

Rev	Date	Description	Drm	Appd
A	25-08-2023	Cupboard doors updated	TSB	ML
-	01-10-2012	Original Issue	TSB	EP

Project

Three Phase Freestanding GRP Meter Cupboard (Suitable For All Tariffs)

Title

Cupboard And Plinth Construction Details

The Intellectual Property Rights (IPR) i.e. Patents, Copyright, Trade Secrets, Design Rights etc., remain strictly the property of 'Jersey Electricity Company plc' and may not be copied and /or reproduced in any form without their 'Express Permission'.



Jersey Electricity plc

The Powerhouse PO Box 45 Queen's Road St. Helier Jersey JE4 8NY
Tel - 01534 505000 Fax - 01534 505011 e-mail - jec@jec.co.uk

Orig. No. **026-R21-6** Revision **A**